

SH-16A

MEC 9-AXIS CNC SINGLE-POINT COILING MACHINE

For wire diameters of $\varnothing 0.5 \sim \varnothing 1.6$ mm / $\varnothing 0.0196'' \sim \varnothing 0.0629''$

Equipped with torsion attachment and initial tension servo motor as standard, it is possible to form compression springs, torsion springs, as well as elliptical springs.

The 3D coiling point moves freely and can be produced at high speed and with high accuracy.



Features

9-axis control with an emphasis on operability

- Control of feed, cut, pitch, and outer coil diameter point, torsion, initial tension, arbor in & out, center slide, and bending assist tools.
- Due to the new dual feed rollers, the load of feed pressure applied to the wire is reduced.
- Rotary or straight cut can be easily switched by simply moving the eccentric pin.
- Utilizing the center slide to cut with the edge of the arbor and wire guide, it's possible to process at high-speed of shapes with straight parts on the spring end. 3D torsion spring processing is possible with using bender assist tool.
- Switching between right- or left-handed can be setting on the screen without touching the mechanical parts.

Support for IOT

The operating status of machine can be monitored through mobile phones or computers, and regular maintenance with preventive maintenance functions can contribute to improved production efficiency.

Improved operability with the MNO2 (MEC New Operation 2) programming software

- The MEC original spring program MNO2 easily organizes important statistics about the machine, including program flow, operating status of each axis, inputs/outputs, jump, etc., as with our other spring machines.
- The program editing function has greatly evolved, and the navigation system function and touch screen make it easier to create programs and shorten the setup time.
- The program for number of coils allows change of the feed, pitch, outer coil diameter, and initial tension on the evolved pitch diagram screen. Making it easier to adjust the basic coils.
- Cylinders, tapers, barrels, and double taper springs can be produced only by inputting specifications on the program. The taper spring can be easy and fine adjusted in 100 steps such as bowl, straight, and mount type by changing the coefficient.
- The automatic spring length correction function based on the capacitance type length inspection, the multi-functional production control screen facilitates product management.



Point area

Servo adjustment mechanism in & out, up/down, and initial tension direction of coiling point

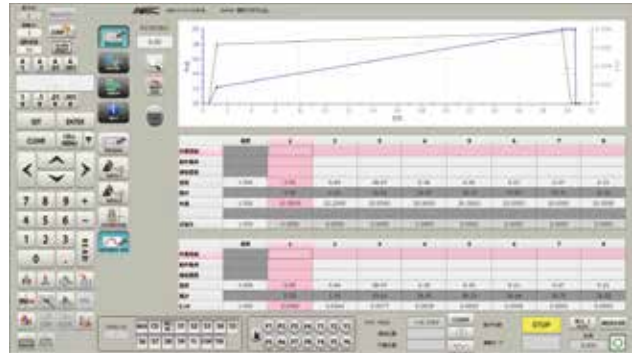

Program for number of coils (cylindrical coils)

The program makes easy to adjust the basic coils.

Specifications

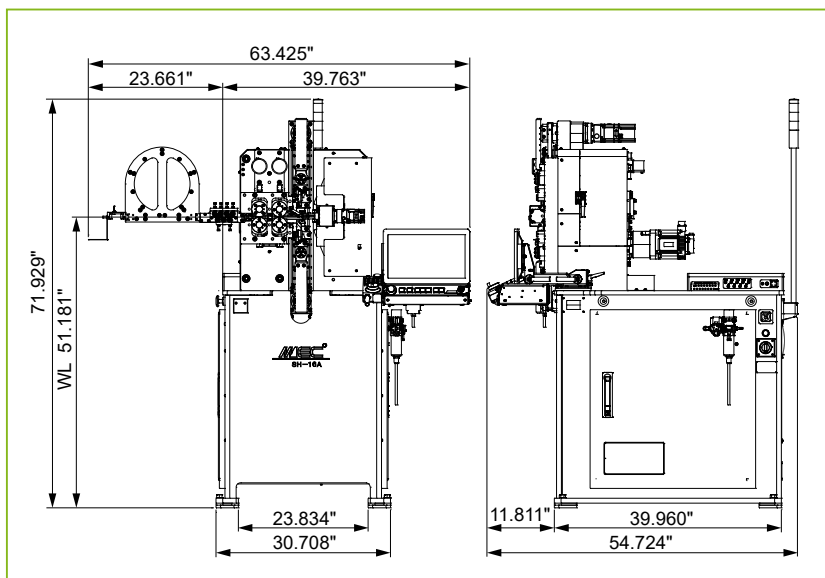

*Resolution: Program input unit, which does not represent accuracy. Specifications are subject to change without notice for product improvement.

Machine name	SH-16A
Wire diameter	ø0.5 ~ ø1.6 mm (ø0.0196" ~ ø0.0629")
Outer coil diameter	ø50 mm (ø1.9685")
Index	D/d 4 or more
Feed axis*	0.0001 mm (0.000004")
Max feed speed	161 m/min (528 ft/min)
Cut axis*	0.001°
Pitch axis*	0.0001 mm (0.000004")
Point axis*	0.0001 mm (0.000004")
Torsion axis*	0.001°
Initial tension axis*	0.001°
Arbor axis*	0.001°
Centre slide axis*	0.0001 mm (0.000004")
Assist axis*	0.001°
Solenoid valves	4 pcs (Max 8 pcs)
Max air pressure	0.5 MPa
Power source	3-phase AC 200V, 15A
Net weight	787 kg (1735 lbs)
Control device	Windows
Software	MNO2
Display	15.6" Full HD touch screen
External memory	USB Thumb drive
Temperature	5 ~ 40°C (41 ~ 104°F)

AMADA PRESS SYSTEM AMERICA INC.

1840 AIRPORT EXCHANGE BLVD., SUITE #200
ERLANGER, KY 41018 U.S.A.

Inquiry

