

DZ-3A

MEC 15-AXIS CNC COILING AND TORSION MACHINE for Ultra-Fine Wire

For wire diameters of $\varnothing 0.02 \sim \varnothing 0.3 \text{ mm}$ / $\varnothing 0.0007'' \sim \varnothing 0.0118''$

The fusion of high-speed, high-precision coiling,
and freely formed torsion processing expands into
new application ranges within the field of ultra-fine wire.

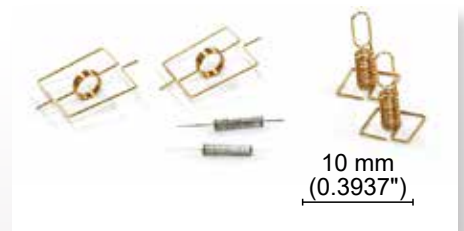
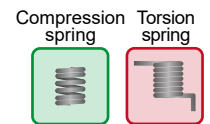

Click
here for
processing
video



Features

- Increasing production possibilities by combining high-speed, high-precision coiling and bending processing**
 - This machine can process coils equivalent to standard coil machines allows flexible bending with three 3D slides. This gives the operator and endless amount of processing possibilities, which he or she could have never imagined before.
 - The dual feed rollers, introduced for the first time for ultra-fine wire, reduce feed pressure applied to the wire, making stable coiling possible.
- 3D slides with versatile modular design capability**

Each 3D slide can be equipped with modular units such as tool changers or rotary servo motors.
- Support for IOT**

The operating status of machine can be monitored through mobile phones or computers, and regular maintenance with preventive maintenance functions can contribute to improved production efficiency.
- Improved operability with the MNO2 (MEC New Operation 2) programming software**
 - The MEC original MNO2 software easily organizes important statistics about the machine, including program flow, operating status of each axis, inputs/outputs, jump, etc., as with our other spring machines.
 - The servo motor control enables high resolution and precise operation.
 - The motor sensor system makes every slide a sensor. It is possible to measure the presence/absence judgment with a touch sensor, coiling angle, free length, etc. in 0.001 mm (0.00004") units. The measurement results are displayed in tables and graphs, and easy correction control for each axis is possible.
 - Both torsion and coiling machines have the same programs, whose goal is convenience for the operator.
 - Highly efficient production is supported by a versatile production management and data collection functions.

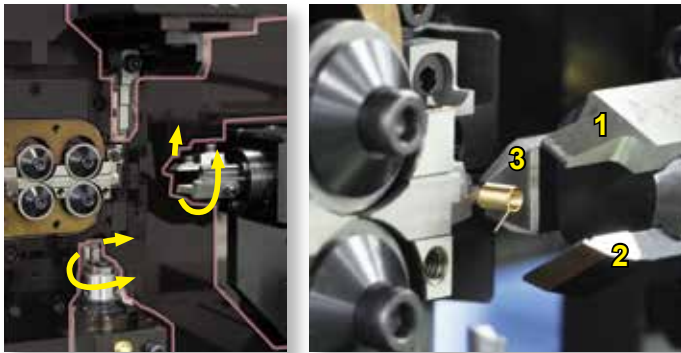

State of processing

The top, bottom, and right slides can be freely controlled individually or in combination. In addition, the tip of the slide can rotate and can be used for spinner bending or as a tool changer for 3 tools.



MNO2 main program and production management screen

Greatly improved operability, with the easy-to-use navigation system and the touch screen, makes it easy to create programs and shortens setup time.

Specifications

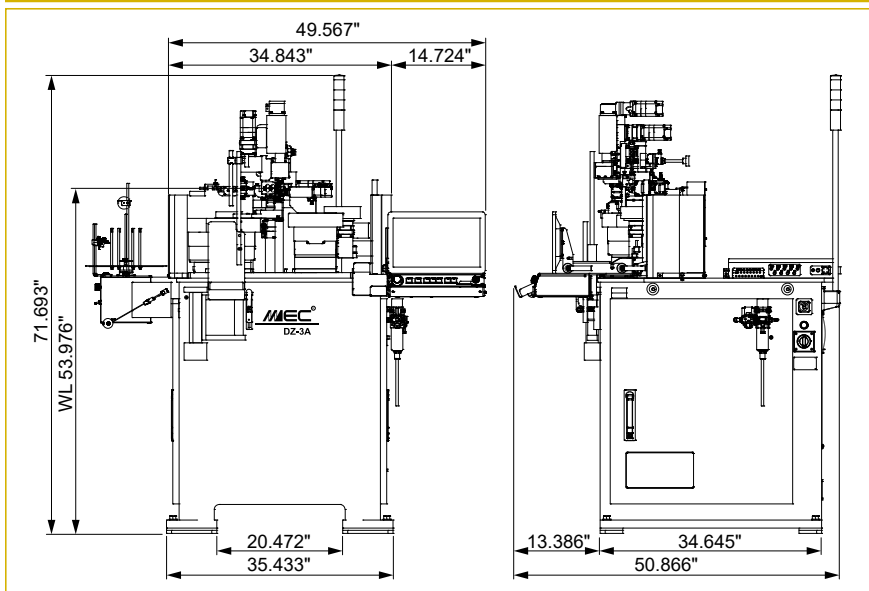

Machine name	DZ-3A
Wire diameter ^{*1}	ø0.02 ~ ø0.3 mm (ø0.0007" ~ ø0.0118")
Outer coil diameter	ø8 mm (ø0.315")
Index	D/d 3.5 or more
Feed axis ^{*2}	0.0001 mm (0.000004")
Pitch axis ^{*2}	0.0001 mm (0.000004")
Arbor front/back axis ^{*2}	0.001°
R/L3D table axis ^{*2}	0.0001 mm (0.000004")
Upper 3D slide axis ^{*2}	0.001 mm (0.00004")
Tool changer axis ^{*2}	0.001°
R-servo axis ^{*2}	0.001°
Solenoid valves	4 pcs (Max 8 pcs)
Max air pressure	0.5 MPa
Power source	3-phase, AC 200V, 15A
Net weight	860 kg (1896 lbs)
Control device	Windows
Software	MNO2
Display	15.6" Full HD touch screen
External memory	USB Thumb drive
Temperature	5 ~ 40°C (41 ~ 104°F)

*1 The option holder for ultra-fine wire can handle wire diameters from ø0.02 to ø0.1 mm (ø0.0007" - ø0.0039").

*2 Resolution: Program input unit, which does not represent accuracy. Specifications are subject to change without notice for product improvement.

AMADA PRESS SYSTEM AMERICA INC.

1840 AIRPORT EXCHANGE BLVD., SUITE #200
ERLANGER, KY 41018 U.S.A.

Inquiry

